

The following drawing is from
 A Continental-DeVaux Company
 Bulletin and would be the
 same for Durant models as
 listed using the Center
 Split Housing wt/double
 wheel bearings:

1930 DURANT 614 Pass. Car and Truck
 1931 DURANT 407 and 610
 1932 DURANT 612, 614, 618, and 619
 1931 DE VAUX-HALL (1st 6,000 Cars)

2002 Mr. Raymond Zenz
 3743 Shamrock Dr.
 Toledo, OH 43615-1227

-13-

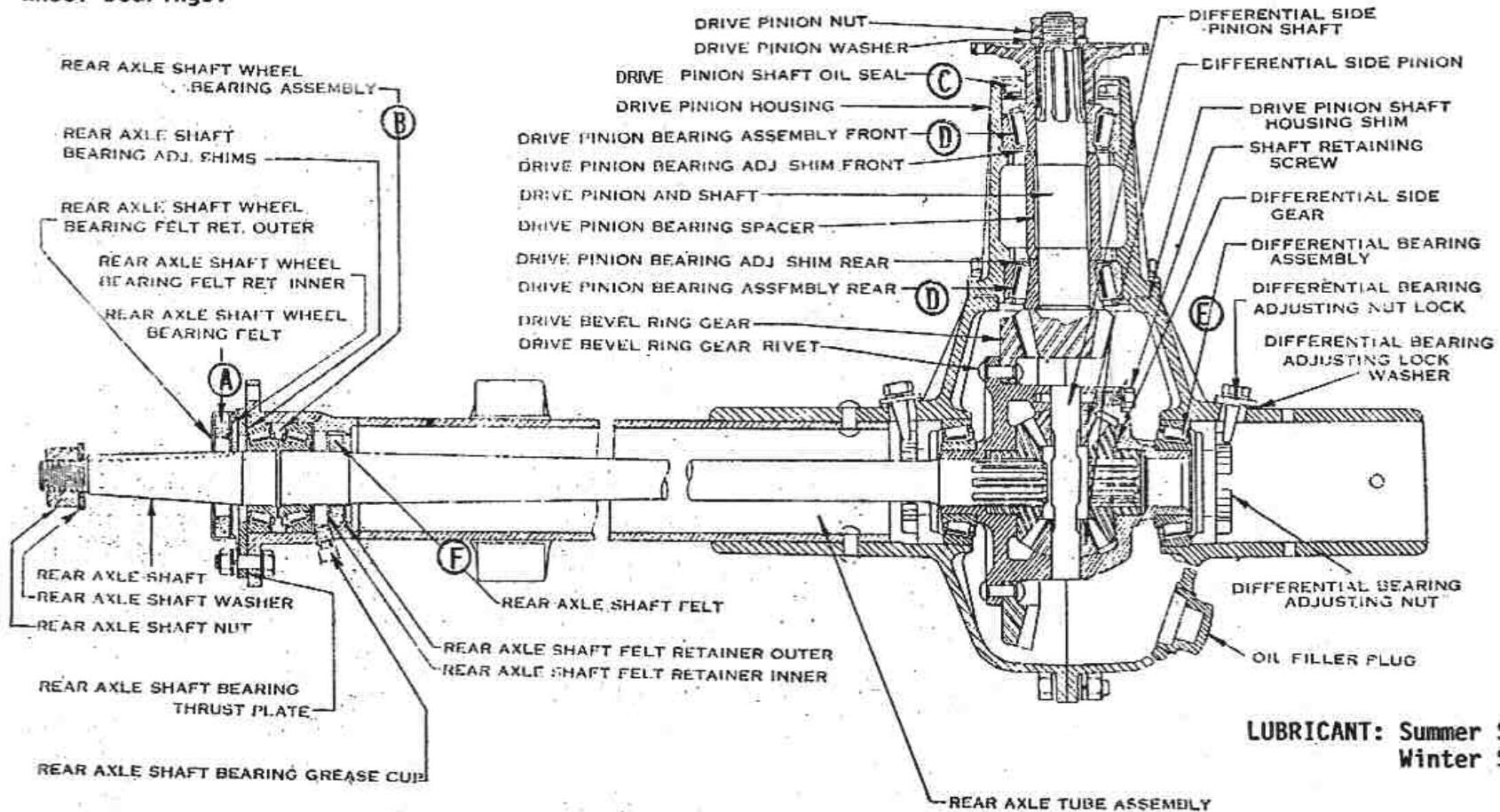

LUBRICANT: Summer SAE-160
 Winter SAE-90

Durant No.	(Req.)	REAR AXLE ASSEMBLY (Center Split Housing) (Double Wheel Bearing)
A. #40565	(2)	(1 15/16" I.D., 3 1/16" O.D., 7/16" thick), C/R 573, National & McCord #T5M-92
B. #40560	(4)	Timkens #14132 cone, #14276 cup
C. #40570	(1)	C/R #16999
D. #40569	(2)	Timkins #3187 cone, #3120 cup
E. #40555	(2)	Timkins #344 cone, #332 cup
F. #40550	(2)	(1 1/4" I.D., 2 1/4" O.D., 3/8" thick) C/R # ?? , National # ??